

nVent Hoffman Purge/Pressurization Manual for Models PLCS1X1 PLCS1X2

This manual covers X - Purge with Leak Compensation

CONTENTS:

- 1. Specification Sheet – LC X - Purge Units**
- 2. Application Suitability**
- 3. Installation, Operation and Maintenance**
 - Section 0. Description and Principle of Operation**
 - Section 1. Installation of the Unit**
 - Section 2. Operation of the Unit**
 - Section 3. Maintenance of the Unit**
 - Section 4. Fault Finding**
- 4. Drawings**
- 5. Certificates**

1. Specification Sheet – nVent Hoffman Purge/Pressurization Units

Model No. (Example):	P L C S 1 X 1	(Note: Not all codes are applicable)
Purge Unit Type P = Purge/Pressurization Unit	←	Purge Interface Unit 1= 110Vac coil for electrical override 2= 230Vac coil IECEX SIR14.0018 / Sira 14ATEX1044
Purging Method LC = Leakage Compensation	←	Approvals / Certifications X = Europe EN60079-0, EN60079-2, EN 61241-0, EN61241-4 Sira 14ATEX1045X
Mounting Style S = Back Plate (Top/Side Mount) 316L Stainless Steel (NROB finish)	←	2813  II 2 (2) G D Ex [px] IIC T6 Gb Ex [p] IIIC T85°C Db Tamb -20°C +55°C IEC IEC60079-0, IEC60079-2, IEC61241-4 IECEX SIR14.0019X
Size 1 = Purge flow rate 8 scfm, 225 NI / min	←	Ex [px Gc] IIC T6 Gb Ex [p Db] IIIC T85°C Db Tamb -20°C +55°C USA / Canada NFPA 496 UL E466718 Class I Div 1 Groups A, B, C & D

For limitations and conditions of use refer to the applicable certificate at the back of this manual.

Supply Pressure:	Must be regulated at inlet Minimum 60 psi / 0.4 MPa / 4 bar Maximum 115 psi / 0.8 MPa / 8 bar
Air Quality:	Compressed air / Nitrogen to instrument quality
Ambient Temperature:	-20°C to + 55°C
Leakage Compensation:	Variable up to 2 scfm / 60 NI/min to compensate for leakage of enclosure
Purge Timer:	Stepped adjustable between 1 minute and 30 minutes
Flow & Pressure Sensors:	"Low Pressure Sensor" 0.2" WC / 50 Pa (0.5 mbar) "Flow Sensor" 1.13" WC/ 280 Pa (2.8 mbar)
Relief Valve:	Opening Pressure: 4" WC / 1 kPa (10 mbar) Purge Flow Rate: 8 scfm / 225 NI/min Material: 316L Stainless Steel Spark Arrestor: Stainless Steel mesh Gasket: Neoprene
Bulkhead Pipe Fittings:	Air Supply: 1/2" NPT Output: 1/2" NPT Signal: 1/8" NPT
Visual Indicators:	Alarm / Pressurized (Red / Green) Purge Complete (Black / Amber)

Action on "Loss of Pressure":

Action on "Loss of Pressure" = "Alarm & Trip" or "Alarm Only". User selectable.

Application Suitability

nVent Hoffman Purge/Pressurization units are certified for use in Hazardous Areas, where the Hazardous Area is non-mining (i.e. above ground) and the hazard is caused by flammable gasses, vapours or dust. Depending on the model, the units may be used in IECEx, ATEX Zone 1(21) - Category 2 and NEC 500 Class I, Div 1.

nVent Hoffman X-Purge units are designed to change the pressurized enclosure internals from a Zone 1 or Class I Division 1 area into a safe area suitable to house general purpose electrical equipment.

This nVent Hoffman Purge/Pressurization unit is designed for use primarily with compressed air. Where other inert compressed gasses are used (Nitrogen, for example) the User must take suitable precautions so that the buildup of the inert gas does not present a hazard to health. Consult the Control of Substances Hazardous to Health (COSHH) data sheet for the gas used. Where a risk of asphyxiation exists, a warning label must be fitted to the Pressurized Enclosure.

The following materials are used in the construction of nVent Hoffman Purge/Pressurization Units. If substances that will adversely affect any of these materials are present in the surrounding environment, please consult nVent Hoffman for further guidance.

Materials of construction (CU):

- Stainless Steel
- Brass
- Neoprene
- Acrylic
- Nylon
- Silicone Rubber
- Polyurethane
- Aluminum
- Mild (carbon) Steel

Materials of construction (PIU):

- Stainless Steel
- Brass
- Aluminum (Ex d / Xp enclosure contains <1% Magnesium)
- Nitrile (O-Rings)

Description and Principle of Operation

All nVent Hoffman Purge/Pressurization units provide:

- a) a method of pressurizing a Pressurized Enclosure (PE) while at the same time compensating for any leakage, together with
- b) a method of purging the enclosure, before power is applied, to remove any flammable gas that may have entered the enclosure while it was not pressurized,
- c) visual indication of the unit status, and
- d) an output to provide remote indication or control.

The general description and function of unit components is as follows:

Control Unit (CU)

The Control Unit (CU) is the heart of the unit. It contains a pneumatic logic circuit specially designed and built to control the functions required for purge and pressurization. For all units this includes air filtration, pressure and purge flow measurement, purge timing, and local visual indication of Pressurized/Alarm and flow sensed. It also provides the outputs for power and remote alarm control to the PIU (nVent Hoffman - Purge Interface Unit).

Relief Valve (RLV) - Figure 1

The Relief Valve unit is fitted to the PE to provide a means of limiting the maximum pressure experienced by the PE during operation. The RLV incorporates a Spark Arrestor to prevent sparks being ejected from the PE into the classified area and is combined with the flow measurement mechanism.



Figure 1 Relief Valve

Purge Interface Unit (PIU)

The Purge Interface Unit is assembled to the Control Unit. The CU provides the PIU with the necessary pneumatic signals to provide an alarm and power switching to the PE. The PIU is built into a flameproof/explosion-proof enclosure. The PIU threaded joint between the cover and the enclosure body forms a flame path.

Leakage Compensation (LC) Pressurization

Initially a high flow of protective gas is passed through the enclosure. This flow is verified and performs the purging phase of the operation. When the purging phase is completed – i.e. the purge time has elapsed - the flow of protective gas is provided via an adjustable Leakage Compensation Valve (LCV) so that it just compensates for any leakage from the PE in addition to maintaining its pressurization. If leakage is less than 5 l/min then the LCV will be awkward to set. You will find that the RLV spring will cycle open and closed. If this happens contact nVent Hoffman.

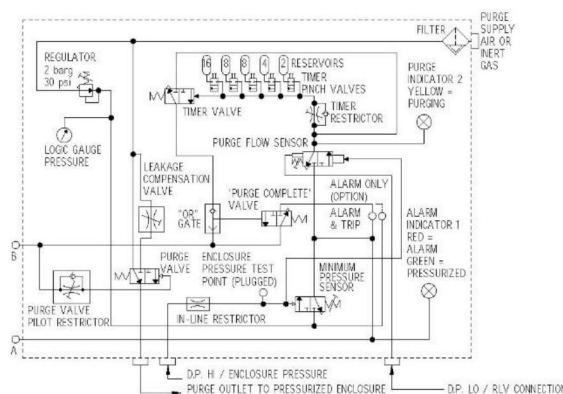

Figure 2 Leakage Compensation Circuit Diagram

Control Unit Outputs

The functions of the CU outputs are signals to initiate the power/disconnect control and remote alarm/pressurized indication via the PIU. This is done with pneumatic signals from the CU to the PIU. The Power output provides a pressure output to supply power to the PE. Alarm output provides a passive signal to indicate remotely when the enclosure is not pressurized and an active signal when pressurized.

The lack of any output signal indicates incomplete purge and an alarm condition.

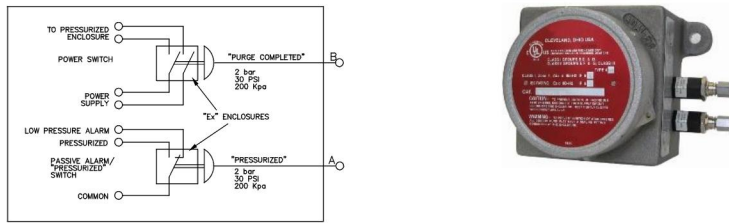

Figure 3 Typical nVent Hoffman - Purge Interface Unit (PIU)

Installation of the Unit

The nVent Hoffman Purge/Pressurization unit is designed for use under normal industrial conditions of ambient temperature, humidity and vibration. Please consult nVent Hoffman before installing this equipment in conditions that may cause stresses beyond normal industrial conditions. The nVent Hoffman Purge/Pressurization unit shall be installed in accordance with relevant standards, such as IEC / EN 60079-14, NEC 500, NFPA 496 and any local codes of practice that are in force.

The nVent Hoffman Purge/Pressurization units consist of the following two components:

Control Unit (CU) with Purge Interface unit (PIU)

The nVent Hoffman Purge/Pressurization unit should be installed either directly on or close to the PE. See mounting details. Generally, the most convenient arrangement is to install the CU/PIU on the top of the PE. The CU must be mounted vertically. The CU/PIU can be mounted on the side of the PE using the rear mounting fixings. The piped connections to the PE should be made using metallic tube through suitable bulkhead connections. The CU/PIU can be remote mounted and should be installed as close as possible to the PE. It should be installed so that the unit indicators and certification labels may be readily observed.

Relief Valve (RLV)

To achieve efficient purging the points where air enters and exits the PE should normally be at opposite ends of the PE. These items must be mounted vertically. The RLV should be situated at the bottom, or on the side of the enclosure at the bottom, when the CU is top mounted on the enclosure, thus achieving top to bottom purging. The purge air may be piped within the PE to ensure purging of potential dead air spots. It is important that the interior and exterior of the Spark Arrestor is kept clean and debris is not allowed to accumulate which might affect the calibration of the device. The exterior of the Spark Arrestor should not be painted or blocked off in any way.

Protective Gas Supply

The nVent Hoffman Purge/Pressurization unit should be connected to a protective gas supply which is suitable for purging and pressurization. The air supply to the filtration unit must be clean, nonflammable, from a non-hazardous area and free from water and oil to BS ISO 8573-1: 2001 Class 2.2.1 or relevant local standards. This is typically referred to as "Instrument Air Quality".

Solid Particles:	0.5µm < particle size ≤ 1µm, maximum 1000 particles/m ³
Humidity:	-40°C* pressure dew point
Oil content:	≤0.01mg/m ³ concentration total oil

* For applications where $T_{amb} \leq 0^{\circ}\text{C}$, the air supply should be Class 2.1.1, with Humidity: -70°C pressure dew point.

Although equipment will operate with lower air quality, the operational life of the unit may be adversely affected. The equipment that is being protected may also suffer from poor air quality.

The minimum air supply pressure should be 4 bar/ 60 psig / 4MPa. It is important that the compressed air / inert gas supply is capable of delivering the quantity required for purging at normal purge flow rate, maintaining the minimum pressure. This means ensuring adequate size of pipe and airline accessories. Over 80% of commissioning problems reported are due to **inadequate sized piping or air supply**. Although the nVent Hoffman Purge/Pressurization unit includes a filter, the compressed air / inert gas supply should have a dedicated local filter.

Purge Air Connection from CU to PE

When the CU is directly top mounted onto the PE, no connection will normally be necessary, as the purge air will discharge into the PE directly. When the CU is not top mounted, or where internal air distribution is necessary a connection should be made from the purge air outlet on the CU (normally 1/2" NPT Female), via pipe (rated at least to the supply pressure) to the PE. This should be kept as short as possible and should be adequately sized to ensure that the full purge flow can be delivered.

CU to Enclosure Pressure Monitor Connection

When the CU is directly top mounted onto the PE, no connection will normally be necessary, as the enclosure pressure monitor point will sense directly inside the PE. Only if the CU is not directly mounted or if there are fans, which may create localized low-pressure areas within the PE, it is necessary to pipe this connection. The connection is made to the enclosure pressure sensor fitting (1/8" NPT Female) on the CU. There is virtually no flow in this circuit, so small bore tube may be used. nVent Hoffman recommends 4mm (5/32") O/D nylon tube. Make sure that all connections are free of leaks.

CU to Flow Sensor Connection

A dedicated Purge Flow Sensor measures the differential pressure between the "DP HI (High) / Enclosure Pressure" and the pressure in the monitoring device at the back of the RLV "DP LO (Low) RLV Connection". nVent Hoffman recommends a 6mm (1/4") OD nylon tube to connect the CU to the RLV.

PIU - Power Supplies and their Isolation

The PIU provides power isolation but all power entering the PE shall be provided with a means of isolation. This requirement also applies to any external power sources, which are connected to equipment such as "volt-free" or "dry" contacts within the PE. Printer signal, network cards, etc need isolation.

Exception: Power to other apparatus that is already suitable for the hazardous area need not to be isolated by the nVent Hoffman Purge/Pressurization unit. In all cases the application and the isolation of the power must be controlled by the nVent Hoffman Purge/Pressurization unit.

Adjustments and Settings

Purge Time

If no specific purge test has been performed on the PE, the volume of the PE must be determined by the User and the necessary purging time calculated based on the purge flow rate specified by the "standard" being used. It is the User's responsibility to verify or enter this data on the PE and/or nVent Hoffman Purge/Pressurization unit nameplate. Ask nVent Hoffman if in doubt.

The IEC / EN 60079-2 permits 5 free volume changes and an example of the calculation is as follows:

If the PE external dimensions indicate an internal free volume of 500 Litres then,
$$\frac{500 \text{ litres enclosure volume} \times 5 \text{ volume changes}}{225 \text{ litres/minute purge flow rate}} = 12 \text{ minutes purge time}$$

If the PE is a motor, experience of purge testing shows that it is prudent to multiply the motor internal "free" volume by ten to get the purging volume.

$$\frac{500 \text{ litres enclosure volume} \times 10 \text{ volume changes}}{225 \text{ litres/minute purge flow rate}} = 23 \text{ minutes purge time}$$

The following applies for NFPA 496 standards where 4 complete volume changes are permitted for enclosures except when the PE contains a motor when 10 volume changes are required. If the PE external dimensions indicate a total volume of 8 ft cu. then,

$$\frac{8 \text{ cubic foot enclosure volume} \times 4 \text{ volume changes}}{8 \text{ scfm purge flow rate, (see above)}} = 4 \text{ minutes purge time}$$

If the same PE contains a motor, then,

$$\frac{8 \text{ cubic foot enclosure volume} \times 10 \text{ volume changes}}{8 \text{ scfm purge flow rate, (see above)}} = 10 \text{ minutes purge time}$$

The standard nVent Hoffman Purge/Pressurization units have a digital pneumatic timer system as shown in Figure 4.

The purge time is set by opening / closing the pinch valve so that the sum of the open valve times equals or exceeds the required purge time. **At least one valve must always be open, and the screws must be at the appropriate limit of travel. Do not over tighten.**

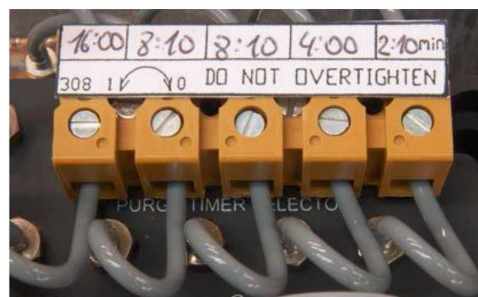

Figure 4 Timer Block

Action on Loss of Pressurization

The action on loss of pressurization is the responsibility of the User. The action on loss of pressurization can be set to ALARM ONLY (AO), or ALARM AND AUTOMATIC DISCONNECT OF POWER (A&T).

The action on loss of pressurization is set by moving the jumper tube (see Figure 5 Action on Loss of Pressurization Jumper Tube). The standard setting is Alarm and Trip where the link is from C to A&T, with a plug in AO. Changing to Alarm Only (AO) is User adjustable by moving the link from C to AO, and plugging A&T.



Figure 5 Action on Loss of Pressure Jumper

Internal Gas Release

If the PE contains an internal source of release of flammable gas or vapor, the procedures for assessment of the release as given in NFPA 496 or IEC / EN 60079-2 should be used. The User must verify that the specifications of the unit e.g. pressure and type of protective gas are correct for the specific application.

Multiple Enclosures

More than one PE can be protected by a single unit. Where PEs are connected and purged in "series" e.g. "Daisy Chained", the RLV should be fitted on the last enclosure with the Purge Inlet connected to the first enclosure. The bore and length of the pipe or conduit used to interconnect the enclosures is critical and will determine the maximum pressure experienced by the first enclosure in the series. Generally, the pipe internal diameter should not be less than 25mm (1"). Too small of a pipe can result in over pressurizing all but the last enclosure. PEs should not be connected in parallel.

Commissioning

First, verify that the unit has been installed in accordance with this manual.

Specific commissioning information for the PIU:

- Once the CU with PIU has been installed, the cable glands, conduits and earth connections shall be inspected for correct installation before the unit is put into service.
- Apply a thin layer of grease (provided) onto the threads of the PIU cover.
- The cover must be correctly fitted and the cover locking device secured.
- If the commissioning is being carried out in the hazardous location, appropriate precautions must be taken to prevent an accident. A relevant "Hot Work Permit" or similar must be obtained from the appropriate authority and regulations followed.

Disconnect the supply pipe from the inlet to the nVent Hoffman Purge/Pressurization unit and blow it through for at least 10 seconds per meter(3ft) of length to remove any debris or condensation.

Connect a temporary pressure gauge or water manometer to the PE or nVent Hoffman Purge/Pressurization unit pressure test point (Remove the red plug on the low pressure sensor and connect 4mm OD nylon tube). (Figure 6)



Figure 6 Pressure Test Point

It is advisable to install an external shutoff valve before the Purge/Pressurization unit, with the same, or larger, thread size as the CU inlet fitting upstream of the connection.



Figure 7 Leakage Compensation Valve (LCV)

- Open the Leakage Compensation Valve (LCV) fully, turn counter-clockwise. Clockwise will reduce the flow and counter-clockwise will increase the airflow. (Figure 7)

- Open the supply regulator SLOWLY, supplied by Others, and allow the PE pressure to rise until the RLV opens. Check that the RLV opens at or below the figure specified in the documentation. Note tolerance of ± 2 mbarg / 0.8" WC / 200Pa
- Repeat the above test several times.
- Open the supply regulator to 4 barg, max 8 barg / 60 and 115 psi / 400 and 800 kPa and the purging flow will start.
- Check that the internal logic gauge reads 2 barg /30 psi / 200 kPa

At this time the "Alarm/Pressurized" indicator should be green and the "Purging" indicator should be yellow. If the yellow indicator remains black the flow through the RLV is below the minimum for which the flow sensor has been calibrated.

- Check the air supply pressure at **the inlet to the control unit while purging is taking place**. It must be above the minimum specified above.

The purge timer will start as soon as the "purging" indicator turns yellow. Check that the time delay between the "purging" indicator turning yellow and the application of power to the PE is not less than the minimum time required for purging the PE. Times in excess of the minimum are permitted and a tolerance of +20% is normally acceptable. If the time is too short, it must be increased accordingly.

After power to the PE has been applied via the CU/PIU the purging valve will close and the air flow into the PE will be controlled by the LCV. The initial setting of fully open will normally be too high. It should now be adjusted to set the PE operating pressure.

There are three possible unit fault situations that can occur:

- a) Air continues to come out through the RLV Spark Arrestor after power has been applied in considerable quantity. The LCV is much too far open, and the air flow is holding the RLV open continuously. Close the LCV slowly. The PE pressure will start to fall as the flow decreases but eventually the RLV will close and the enclosure pressure rise again. At this point the RLV may start to open intermittently as the PE pressure rises to the point where it exceeds the RLV opening pressure. When the RLV opens the pressure will fall quickly to the point where the RLV recloses and the enclosure pressure starts to rise again. This is entirely normal for this type of RLV and is remedied as indicated below:
- b) If the RLV is opening intermittently the LCV is slightly too far open. When the RLV opens the enclosure, pressure falls quickly to the point where the RLV re-closes and the enclosure pressure starts to rise again. This is entirely normal for this type of RLV and shows that it is working correctly. Continue then to close the LCV until the cycling stops and the enclosure pressure starts to fall. Carefully adjust the LCV until the PE pressure is approximately 50% of the RLV opening pressure and stable. This pressure may be around 5 mbarg / 2" WC / 500 Pa and will be the "normal operating pressure".

We recommend that the setting of the minimum pressure sensor be checked at this time. Note the position of the LCV knob. (A pencil mark placed on the knob at "12 O'clock" can be used). Slowly lower the PE pressure by closing the LCV further, counting the number of turns from the "normal working pressure" position. Note the pressure at which the "alarm/pressurized" indicator turns from green to red and check that it is not lower than the figure given in the documentation. Check also the "Alarm" electrical contacts. As soon as the "alarm/pressurized" indicator turns red, the unit will start to re-purge. If Alarm and Trip function is selected the enclosure power will be switched off.

While it is re-purging return the LCV to its "normal working pressure" position so that, at the end of purging, the enclosure pressure should immediately settle down at the correct "normal" pressure.

- c) If, at the end of purging, the PE pressure falls below the minimum pressure sensor setting and the LCV is fully open, the unit will start to purge again. This is indicative of excessive leakage from the enclosure. In this case, check the enclosure for leakage, and reduce or eliminate the leaks. When leaks have been eliminated, the enclosure should stay pressurized at the end of purging. If the RLV action is as described in a) or b) above. Proceed as described above.

Operation of the Alarm / Pressurized contact can be tested as follows:

- With the air supply turned off, there should be continuity between the A and C terminals, and no continuity between the C and P terminals.
- Close the enclosure door and turn the air supply on. The purge should begin, and the Pressurized indicator on the CU should change from "Red" to "Green". There should now be continuity between the C and P terminals, and no continuity between the C and A terminals of the PIU.

PIU - Operation of the power switching contacts can be tested as follows:

- With the air supply off, the power switching contacts should be open circuit.
- Close the enclosure door. Turn on the air supply. The purge cycle should begin.
- Once the purge cycle has been completed the power switching contacts will close. Both pneumatic connections between the CU and PIU are now pressurized,
- Ensure the pneumatic connections do not leak.

The final check is the most important and must not be ignored.

- The enclosure should be pressurized, a purge cycle completed, and the power contacts closed.
- Turn the air supply to the CU off. After a few seconds the enclosure will lose pressure and the following should happen
 - The Pressurized indicator on the CU should change from "Green" to "Red".
 - The power contacts should open disconnecting power to the enclosure.
 - There should be continuity between the A and C terminals, and no continuity between the C and P terminals.
 - The above assumes the CU unit is set to "Alarm & Trip" (i.e. Disconnect) not to "Alarm Only"
- If the final check has been completed successfully, turn on the air supply to the CU.

Normal operation

Turn the air supply on or off to start or stop the unit. After this the pressurizing and purging sequence is entirely automatic

Maintenance of the Unit

The maintenance recommended for the unit consists of the following items, supplemented by any additional local requirements imposed by the local Code of Practice. nVent Hoffman recommends that the commissioning tests be repeated at least every six months.

In addition, the following checks are also recommended at that time:

- Check the RLV and Spark Arrestor. Remove all debris & corrosion or replace with a spare.
- Check the condition of the air supply filter element. Clean or replace as necessary.

At a minimum of six months and/or a maximum of every two years check the following additional items:

- Apparatus is suitable for the Hazardous Location
- There are no unauthorized modifications
- The air supply must be to the correct quality, refer to section Air Quality
- The interlocks and alarms function correctly
- Approval labels are legible and undamaged
- Adequate spares are carried
- The action on pressure failure is correct
- Inspect the condition of the cover/body thread for any signs of damage or corrosion.
- Repeat the commissioning tests to check correct operation of the unit.

Pressure sensor calibration If it is decided that the minimum pressure /purge flow sensor needs recalibrating it must be returned to nVent Hoffman for this service.

Filter cleaning If the filter element needs cleaning, the filter bowl can be unscrewed and removed. The filter element also unscrews and can then be cleaned in soapy water. Do not use solvents on any part of the filter assembly.

Fault Finding

If the Purge/Pressurization unit does not behave in the manner described above, there is a fault. Some of the more likely faults are dealt with below. If a cure cannot be affected by following the procedure shown below, please contact nVent Hoffman for further assistance.

The Purge/Pressurization unit has been designed for ease of fault finding and the many of the components fitted are plug-in or manifold mounted. Check components by substitution only after establishing that such action is necessary. If the unit is less than 12 months old, parts under warranty should be returned to nVent Hoffman for analysis, with a full report of the fault and the unit serial number.

As with any pneumatic units the greatest enemies are water, oil and dirt in the air supply. For this reason, the air system must always incorporate a dust and water filter. However, dirt can enter from other sources and it is vital therefore that the procedures described in this manual are carried out before using the unit for the first time or following any disconnection of the pipe-work. Failure to perform this work may cause damage that will not be covered under warranty.

Before making the following checks verify that both the main air supply pressure to the purge unit & the regulated pressure to the logic are as specified on the unit specification sheet.

Fault Finding (Leak Compensation Units)

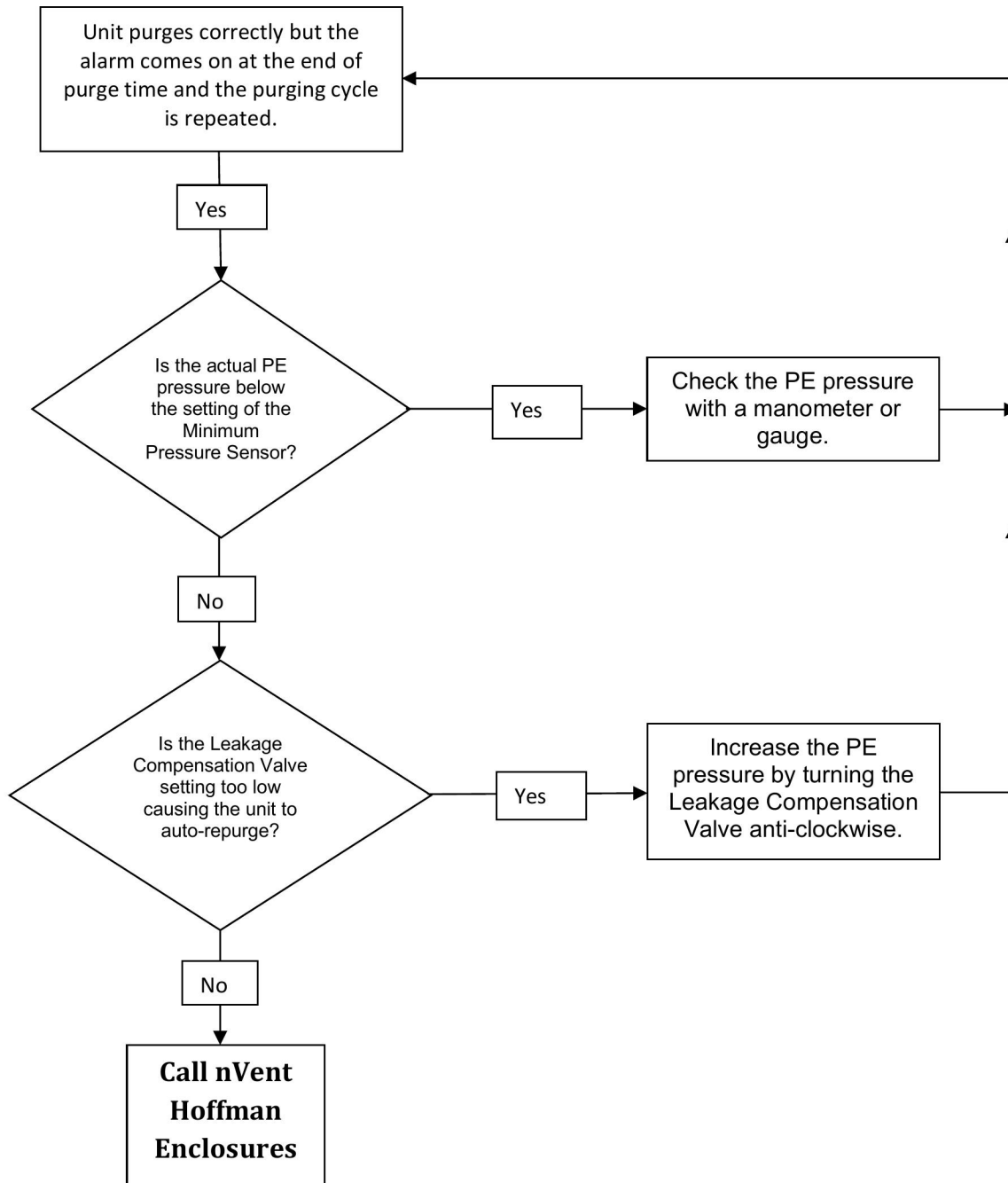

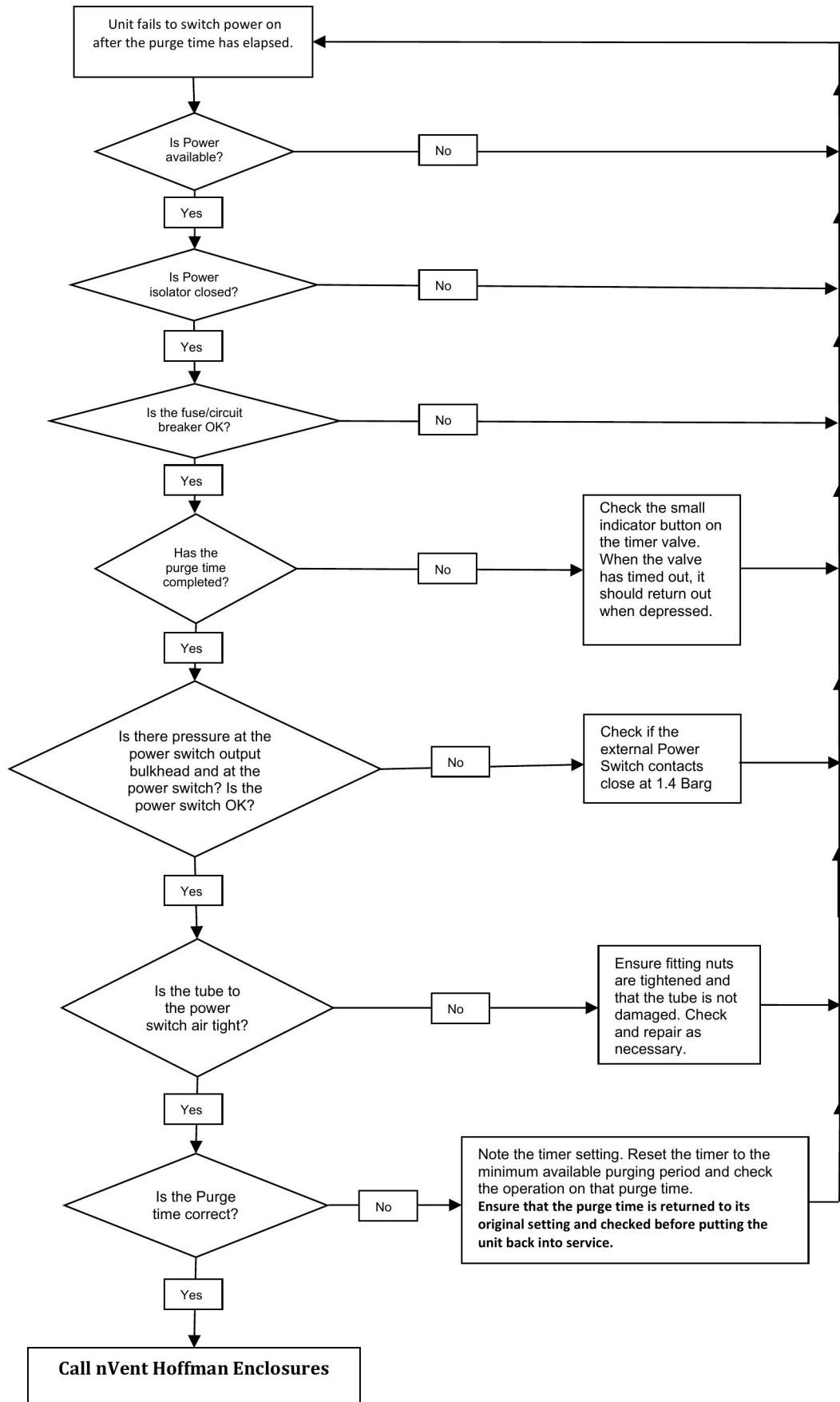

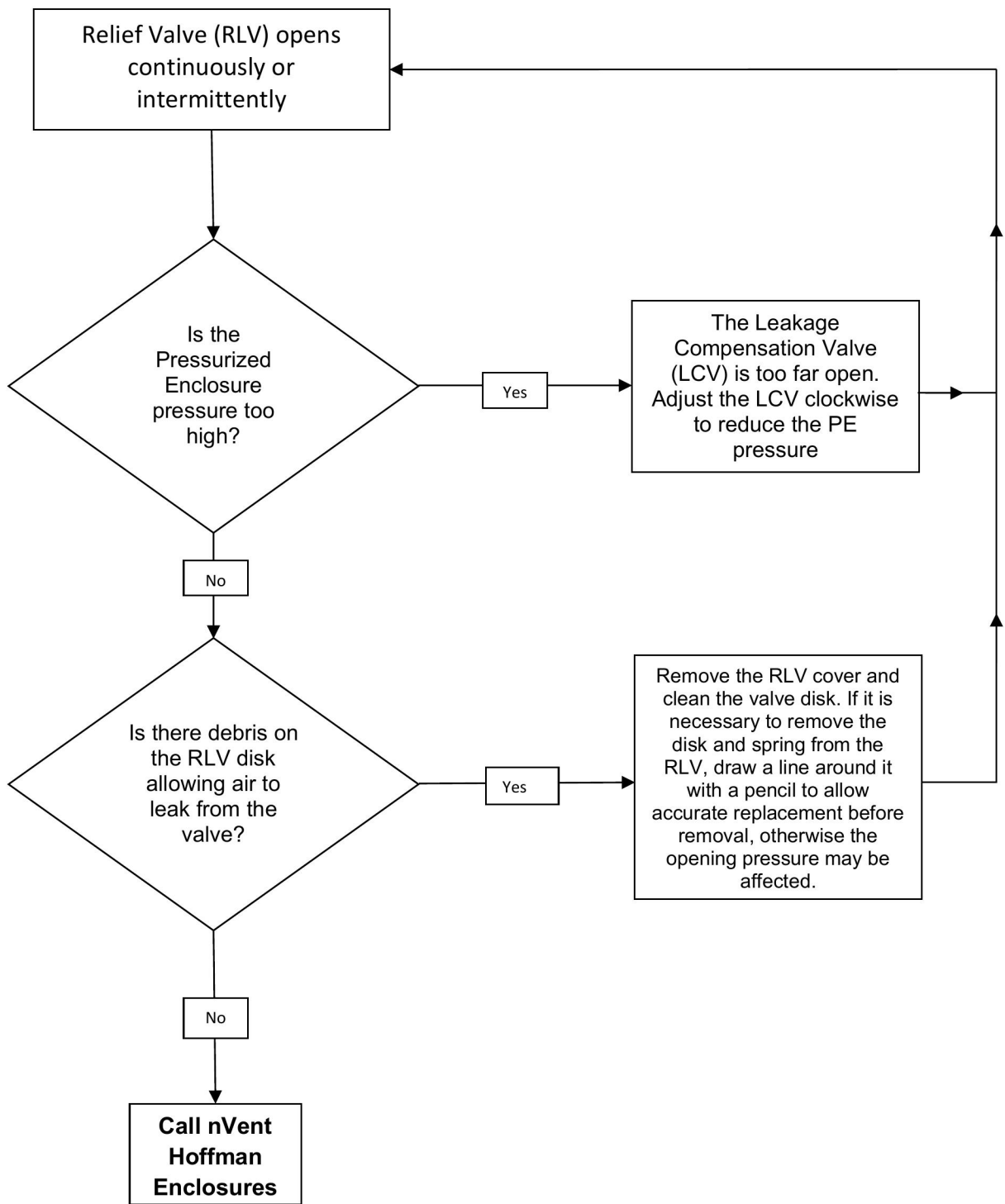

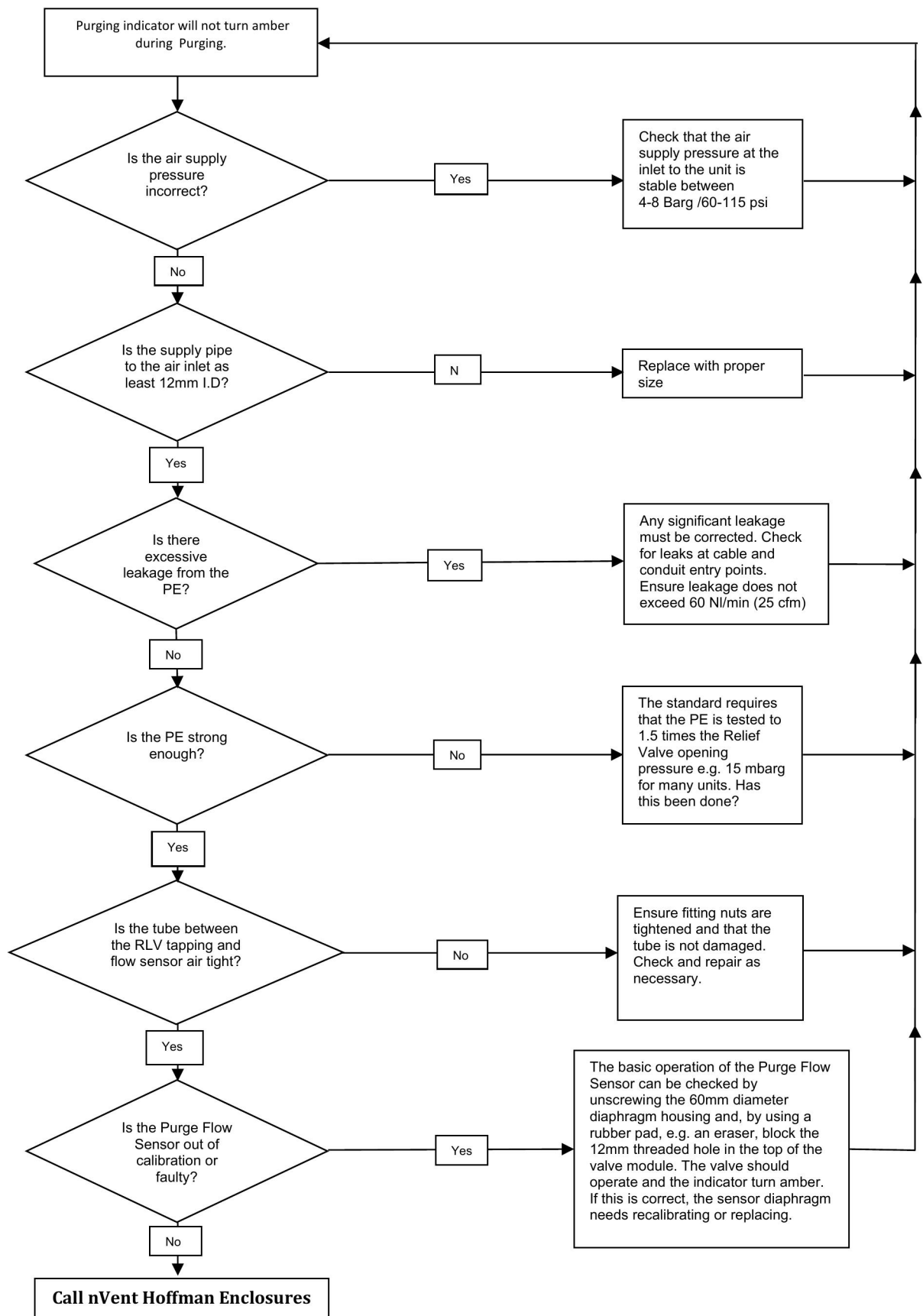

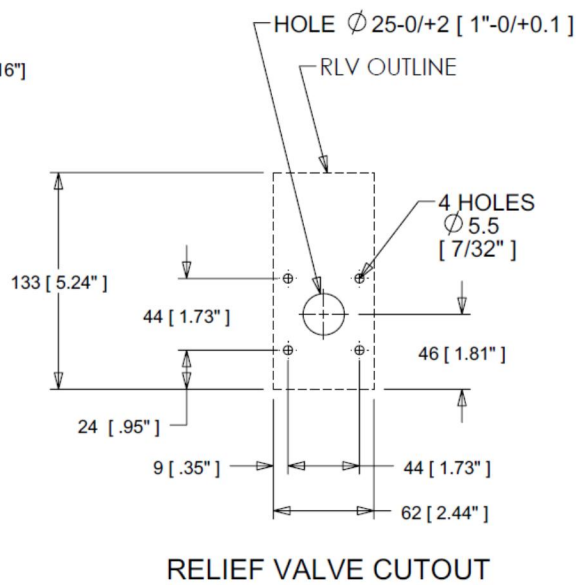
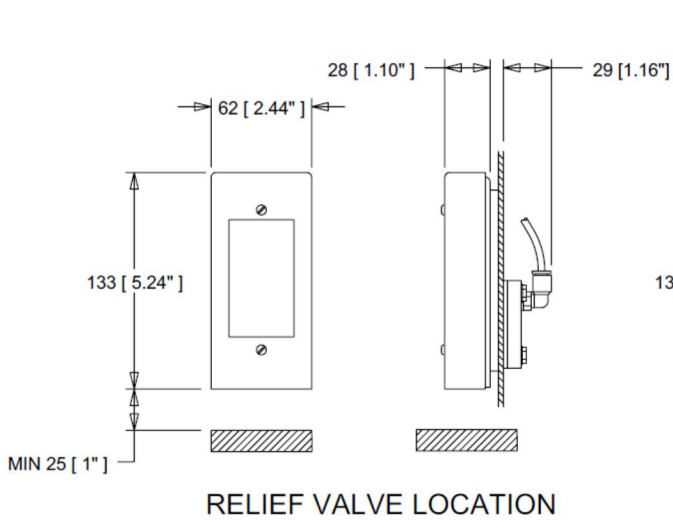
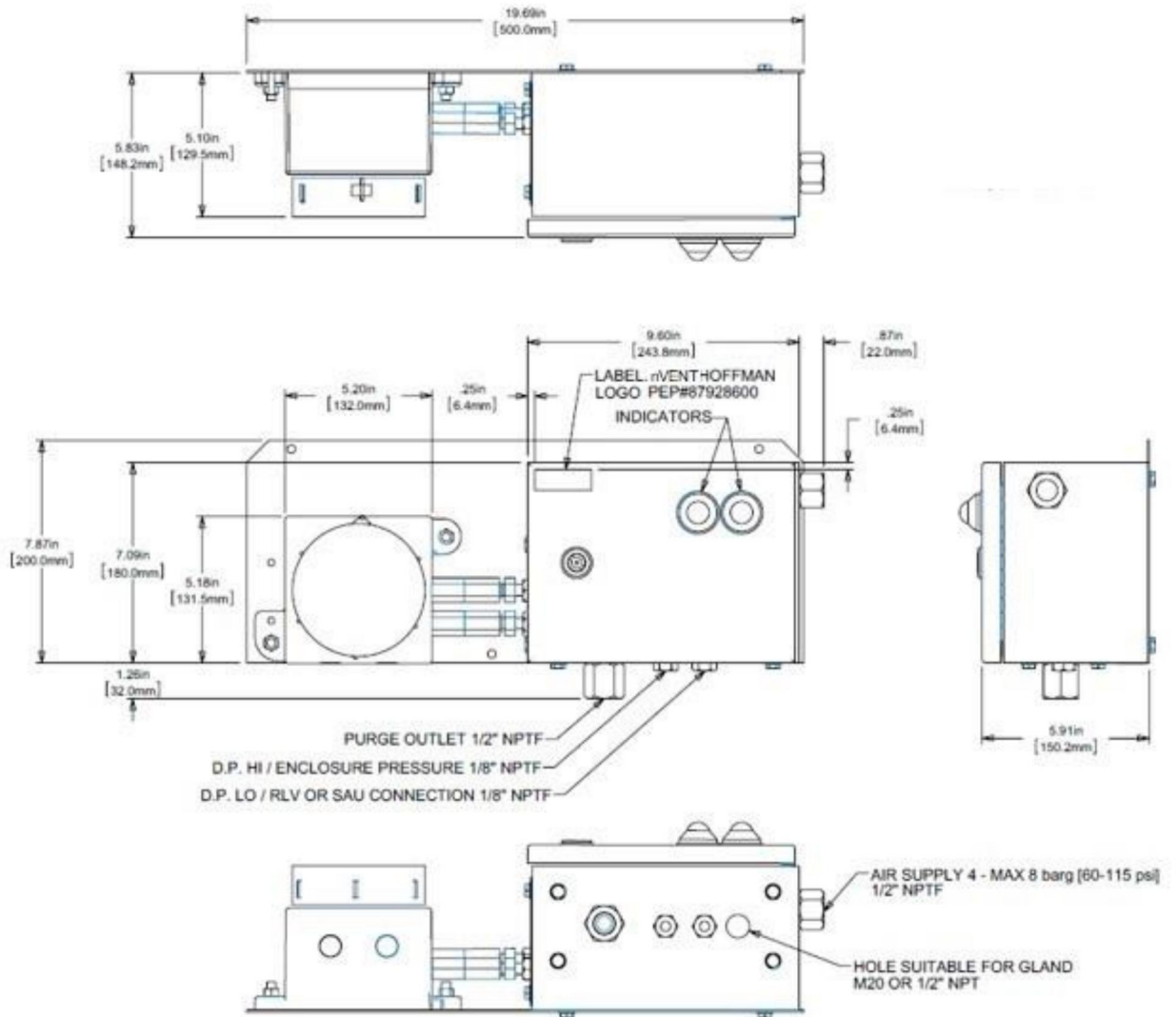

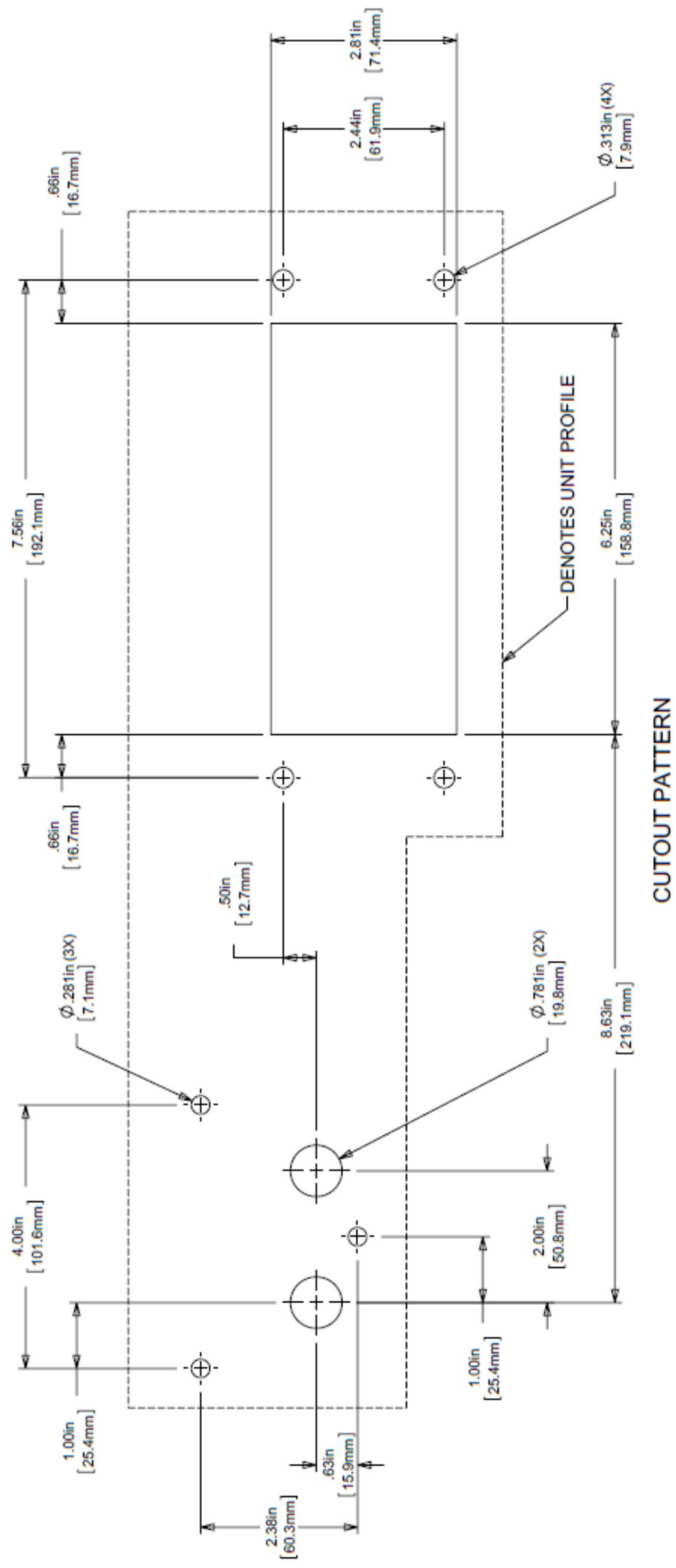

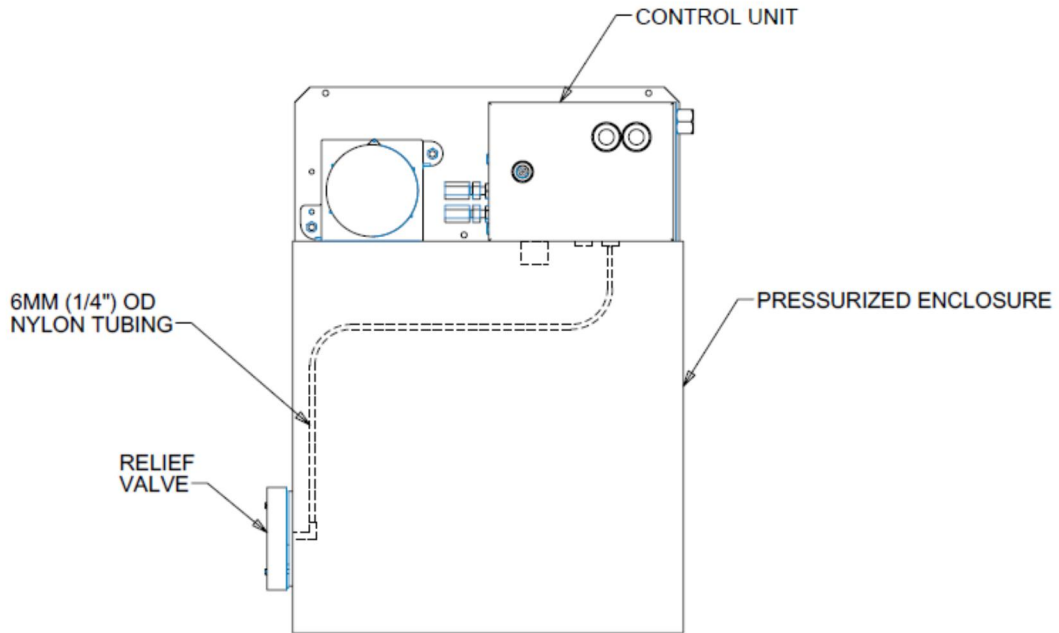

NOTES:

1. CONTROL UNIT AND RELIEF VALVE TO BE MOUNTED IN POSITIONS SHOWN.
2. VENT PURGE AIR INTO TOP OF PRESSURIZED ENCLOSURE AND EXIT THROUGH RELIEF VALVE AT BOTTOM OF ENCLOSURE.

	ALARM INDICATOR		PURGE INDICATOR	
	ALARM	PRESSURIZED	PURGING	PURGE COMPLETE
LEAKAGE COMPENSATION (LC)	RED	GREEN	YELLOW	BLACK
CONTINUOUS FLOW (CF)	RED	GREEN	YELLOW	BLACK

Control Unit

- 1 GAUGE, LOGIC AIR SUPPLY
- 2 LOGIC AIR SUPPLY REGULATOR
- 3 IN LINE RESTRICTOR
- 7 BLACK COLLAR (PLUGGED)
- 8 INDICATOR, "ALARM/PRESSURIZED"
- 9 INDICATOR, "PURGING"
- 13 PURGE FLOW SENSOR
- 14 MINIMUM PRESSURE SENSOR
- 15 MAIN AIR SUPPLY FILTER, MANUAL DRAIN
- 16 PURGE COMPLETE "OR" GATE
- 17 LEAKAGE COMPENSATION VALVE
- 18 TIMER VALVE
- 19 PURGE BOOST VALVE
- 22 PURGE COMPLETE VALVE (BELOW ITEM 17)
- 26 PLUG 4mm
- 33 "ACTION ON ALARM" OPTION PIPE
- 34 ALARM ONLY PUSH-IN FITTING
- 35 ALARM AND TRIP PUSH-IN FITTING
- 76 PURGE TIME SELECTOR

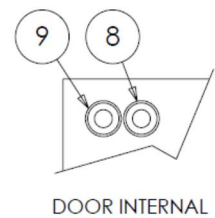
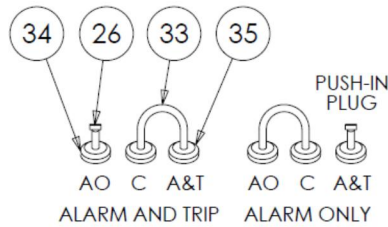
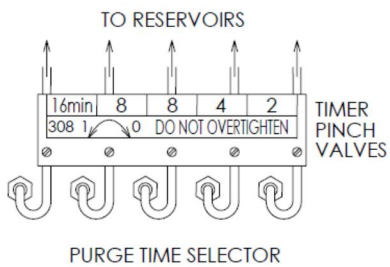
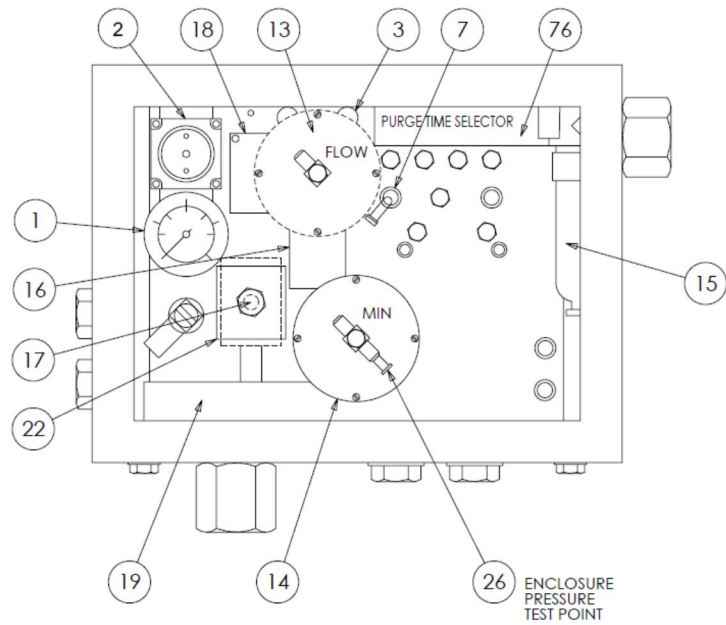

PIU

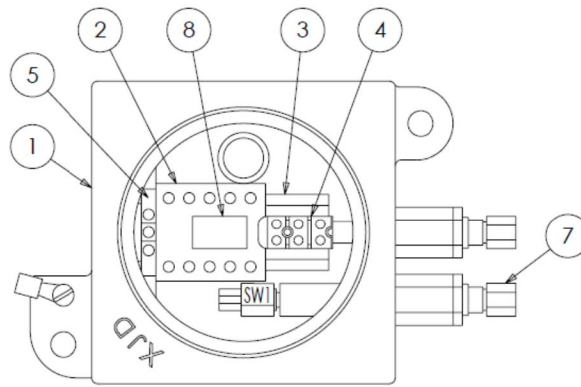

ITEM	DESCRIPTION
1.	Ex d / EXPLOSIONPROOF ALUMINUM HOUSING
2.	CONTACTOR CON 1: UL AND CSA: 3 PHASE: 3HP 480Vac GENERAL USE: 12A 300Vac IEC: AC1 20A 440Vac T<40°C AC1 16A 440Vac T<55°C AC3 9A 400Vac T<55°C AC3 9A 400Vac T<55°C COIL: 50/60Hz AT 40°C: 110Vac FOR PLCB1X1 230Vac FOR PLCB1X2
3.	TERMINAL RAIL
4.	ALARM/PRESSURIZED TERMINAL BLOCK
5.	EARTH TERMINAL BLOCK
6.	POWER INTERLOCK ACTUATOR
7.	ALARM/PRESSURIZED ACTUATOR FOR SW1
8.	UL CSA AND IEC: 6A 125Vac OR 3A 250Vac RATING LABEL

WIRE SIZE FOR CONTACTOR AND TERMINALS: 2.5mm (14 AWG) MAX

Electrical Override Contactor

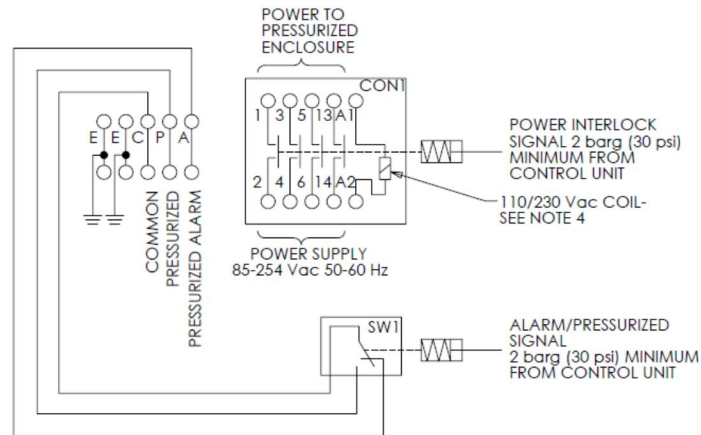

NOTES:

- EXPLOSION PROOF PRODUCTS ARE DESIGNED TO FULFIL THE APPLICABLE REQUIREMENTS OF IEC, ATEX & NEC ARTICLE 500 HAZARDOUS (CLASSIFIED) LOCATION INSTALLATIONS.
- THIS PURGE INTERFACE UNIT IS SUITABLE FOR USE IN THE FOLLOWING HAZARDOUS LOCATIONS:
CLASS I DIVI GROUP B, C & D, UL COMPLIANCE
CLASS II DIV I GROUP E, F & G NEMA 4, 7 & 9
SIRA 14ATEX1044 II 2 GD
ZONE 1 GAS GROUP IIC Ex d IIC T6 (Tamb -20°C TO +40°C) OR T5 (Tamb -20°C TO +55°C)
ZONE 21 DUST Ex td A21 IP6X T80 °C OR T95 °C (Tamb -20°C TO +55°C)
IECEX SIR14.0018
ZONE 1 GAS GROUP IIC Ex d IIC T6 (Tamb -20°C TO +40°C) OR T5 (Tamb -20°C TO +55°C)
ZONE 21 DUST Ex td A21 IP6X T80 °C OR T95 °C (Tamb -20°C TO +55°C)
- MODELS AVAILABLE WITH EITHER 110Vac OR 230Vac COIL.
- COIL IS ONLY USED AS PART OF ELECTRICAL MANUAL OVERRIDE, WHEN REQUIRED.



RSP Supply - 1-888-532-2706 - <https://www.RSPSupply.com>
See the product details here



RSP Supply - 1-888-532-2706 - <https://www.RSPSupply.com>
See the product details here



RSP Supply - 1-888-532-2706 - <https://www.RSPSupply.com>
See the product details here

Hoffman Enclosures, Inc.

2100 Hoffman Way
Anoka, Minnesota 55303-1745 USA
Phone: 763 422-2211

P/N 89108871 Dwg 89109563 A



RSPSupply - 1-888-532-2706 - <https://www.RSPSupply.com>
See the product details here